

394869

# Livret technique à conserver Technical manual to keep

## F - Armoire

Livré démonté : 2 colis  
À monter soi-même

## GB - Wardrobe

Knocked down : 2 parcels  
Self assembly

Temps de montage  
Assembly duration

2H00



x2



Outillage nécessaire  
Needed tools



**CONSEIL** Il est recommandé de mettre une protection au sol pour manipuler les pièces.  
**ADVICE** Put a protection on the floor to handle parts.

F

## IMPORTANT - A CONSERVER POUR DE FUTURS BESOINS DE REFERENCE

*Respecter les instructions de montage et les conseils d'utilisation suivants :*

Vérifier la présence et l'état de la quincaillerie et des pièces avant de débiter le montage.

Le meuble ne doit pas être utilisé si des parties sont cassées, déchirées ou manquantes. Toute partie additionnelle ou pièce de rechange doit être obtenue du fabricant.

Utiliser uniquement l'outillage fourni ou préconisé.

Serrer correctement les éléments de fixation avec l'outillage fourni ou préconisé.

Un mauvais montage, calage ou manutention peut entraîner une fragilisation des assemblages et/ou des pièces.

Les meubles à monter doivent être assemblés par un adulte et jamais par un enfant car certaines pièces présentent un risque d'étouffement.

Tous les éléments de fixations doivent toujours être convenablement serrés et contrôlés régulièrement.

Ne pas déplacer un meuble chargé.

Pour éviter les risques d'incendie, ne pas placer votre meuble à proximité de flammes nues et d'autres sources de forte chaleur, comme les appareils de chauffage électrique ou à gaz, etc.

Conseils d'entretien : Dépoussiérage chiffon sec ; ni alcool, ni solvant. Taches rebelles : éponge légèrement humide.

Pour tout déplacement, les meubles doivent être impérativement soulevés et non poussés ou tirés.

GB

## IMPORTANT - KEEP THIS LEAFLET FOR A NEW CONSULT OF THE ITEMS' REFERENCE

*Be aware and respect the assembling instructions and the following uses advice:*

Verify the presence and the state of the hardware and parts before beginning the assembly.

The piece of furniture must not be used if parts are broken, torn or missing. Any additional part or replacement part must be obtained from the manufacturer.

Use only the supplied or recommended equipment.

Tighten correctly the elements of fixation with the supplied or recommended equipment.

A bad assembly, wedging or handling can cause a weakening of the assemblies and/or of the parts.

Furniture to be assembled must be assembled by an adult and never by a child because certain parts present a risk of suffocation.

All the bindings elements must be always suitably tightened and checked regularly.

Do not move a piece of furniture in charge of.

To avoid fire risks, do not place your piece of furniture near naked flames or other sources of strong heat, as the devices of electric or gas heating, etc.

Dust with dry cloth ; no alcohol nor solvents. Hard to remove stains : slightly damp sponge.

The furniture must always be lifted when moving it.

A LIRE ATTENTIVEMENT

TO READ CAREFULLY

## UP CHENE DORE UI191A

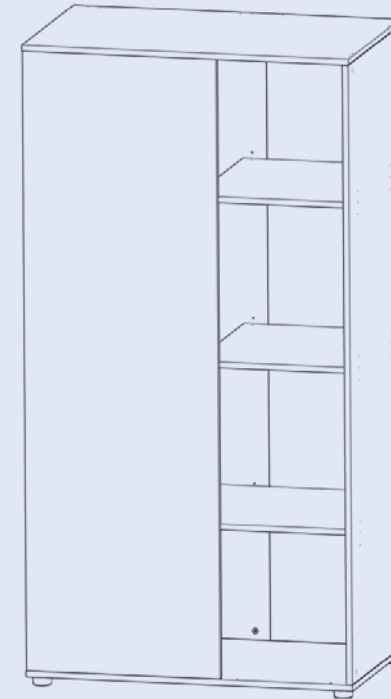

ou  
or

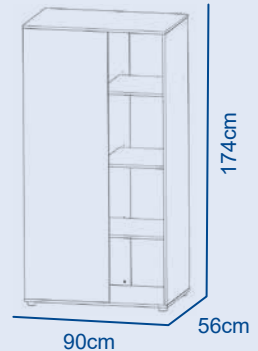
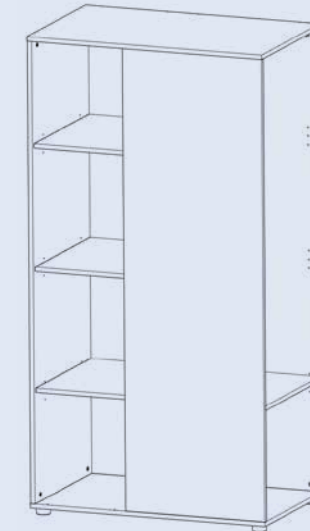

FR  
Donnez ou recyclez  
vos meubles.



Association



Magasin



Déchèterie

<https://quefairedemesdechets.fr>

SAUTHON Industries S.A. au capital de 3.000.000 €  
RCS Guéret B421 195 298 - Code NAF 3109 B  
Z.I. Cher-du-Prat - B.P. 317 - 23007 GUERET  
e-mail: [info@sauthon.fr](mailto:info@sauthon.fr) - [www.sauthon.com](http://www.sauthon.com)



10-31-1969 / Cette entreprise a fait certifier sa chaîne de contrôle / pefc-france.org

édition 11.23

# FICHE TECHNIQUE - SAV à conserver / TECHNICAL SHET - AFTER SALES SERVICE to keep

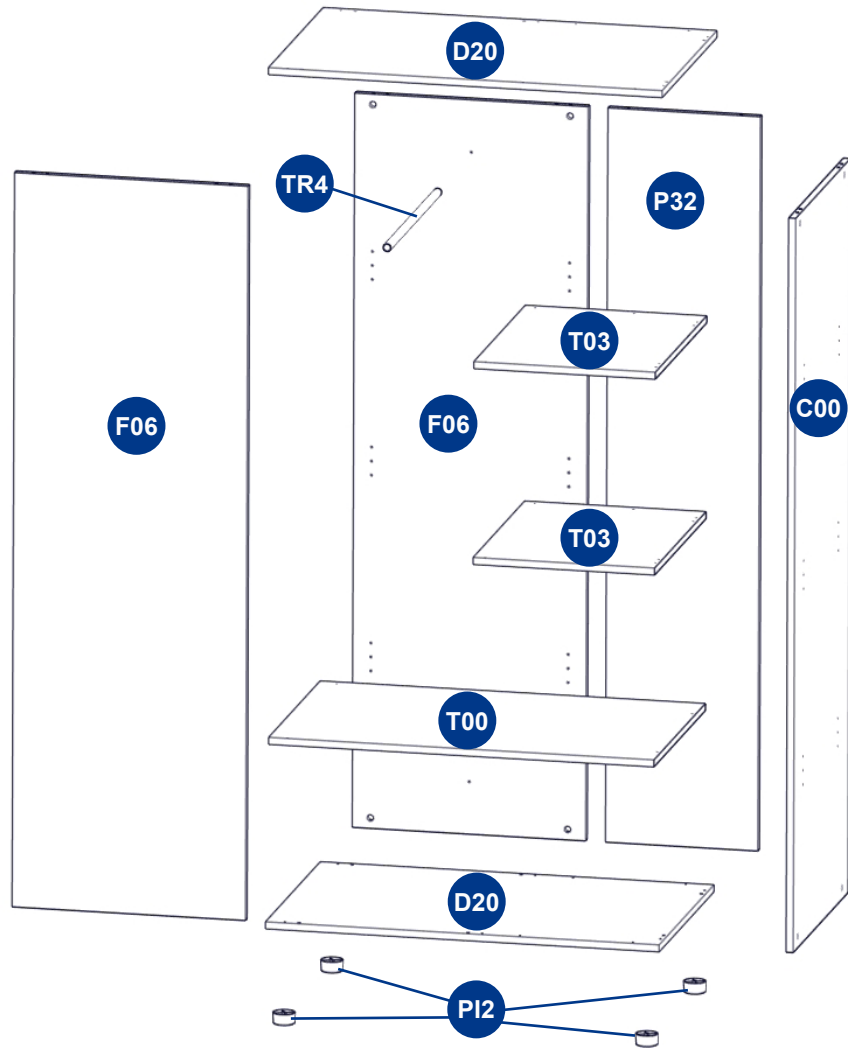

RE-PERE	QTE	COLIS 1/2	REF	SAV
JD	x16	■	134266	
MQ	x16	■	134533	
CF	x12	■	141013	
WK	x8	■	324941	
YY	x6	■	357609	
AC	x10	■	134919	
CW	x2	■	134513	
YO	x2	■	351270	
BB	x2	■	134501	
TX	x4	■	282274	
BS	x2	■	134146	
UA	x1	■	284450	



**Avertissement :** Nous fournissons un nombre de quincaillerie supérieur à celui indiqué dans cette fiche, il est donc normal d'en avoir encore après le montage.

**Warning :** We provide a superior number of hardware than specified in this file, so it is normal to have more of them after assembly.

REPERE	QTE	COLIS 1/2 1507323	COLIS 2/2 1515923	REF	SAV
D20	x2	■		394851	
T00	x1	■		394864	
T03	x2	■		394862	
PI2	x4	■		323034	
TR4	x1	■		394317	
F06	x2		■	394857	
C00	x1		■	394854	
P32	x1		■	394859	

### DEMANDE DE SAV / AFTER SALES SERVICE REQUEST :

**Toute demande de SAV doit être transmise directement au revendeur.** Les produits, dont la date d'achat est supérieure à 2 ans, ne donnent plus droit à une demande de SAV **GRATUITE**. Vous pouvez, néanmoins, adresser votre demande à votre revendeur afin d'obtenir un devis.

**All after sales service claims must be informed directly to the store where the article has been bought.** For more than 2 years purchasing date it will not be possible to claim a **FREE** after sales service. However, information about the price of the claimed pieces will be given in the store where the article has been bought.

Sauthon Industries S.A. au capital de 3 000 000 € - RCS Guéret B 421 195298 - Code NAF 3109B  
 Z.I. Cher du Prat - BP 317 - 23007 GUÉRET  
[sauthon@sauthon.fr](mailto:sauthon@sauthon.fr)

Motif du SAV / Reason of after sales service : .....

.....

.....

.....

1

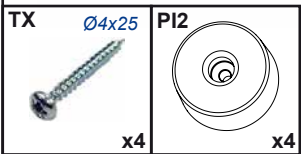
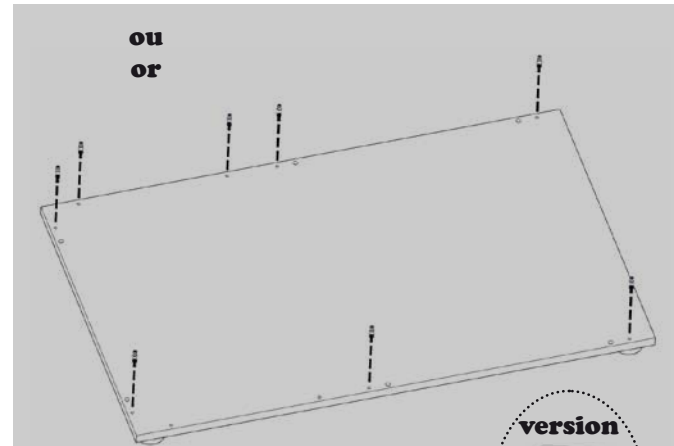
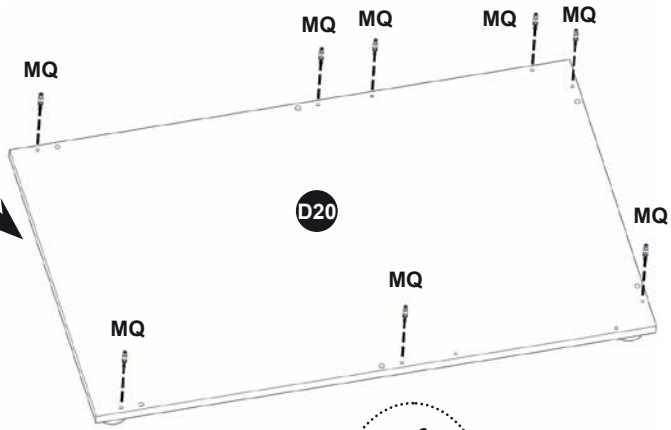
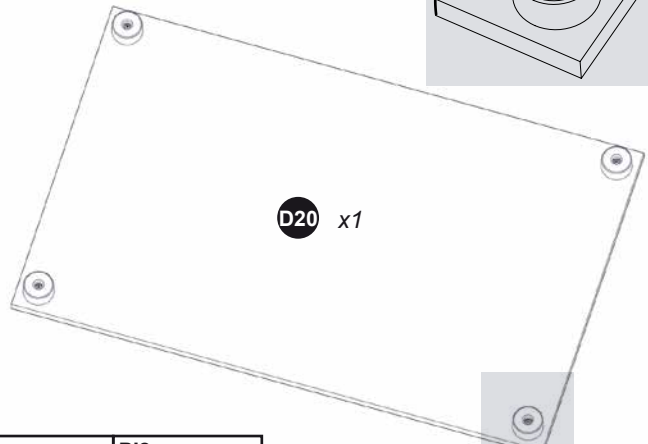
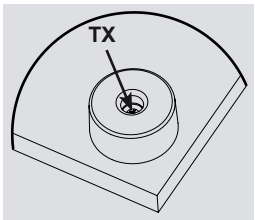

• Voir le gabarit de fixation des pieds en fin de notice.  
 • For binding feet, see the model at the end of the instructions.

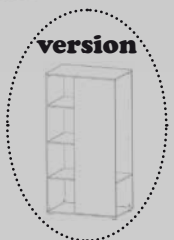
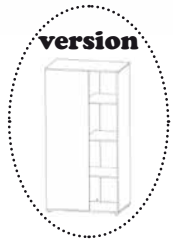

2

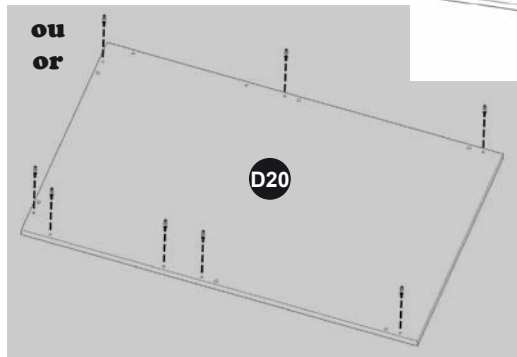
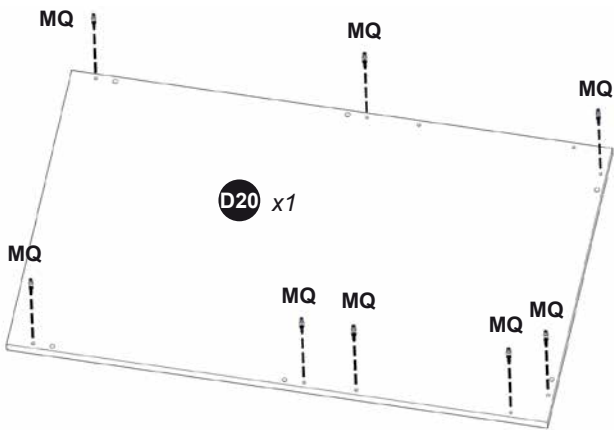

3

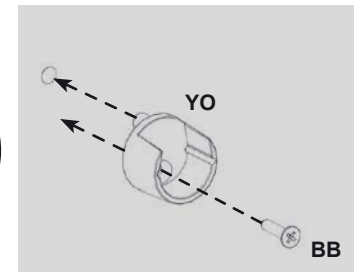
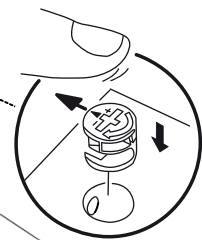
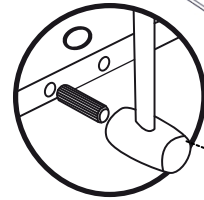
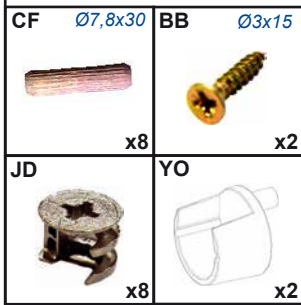
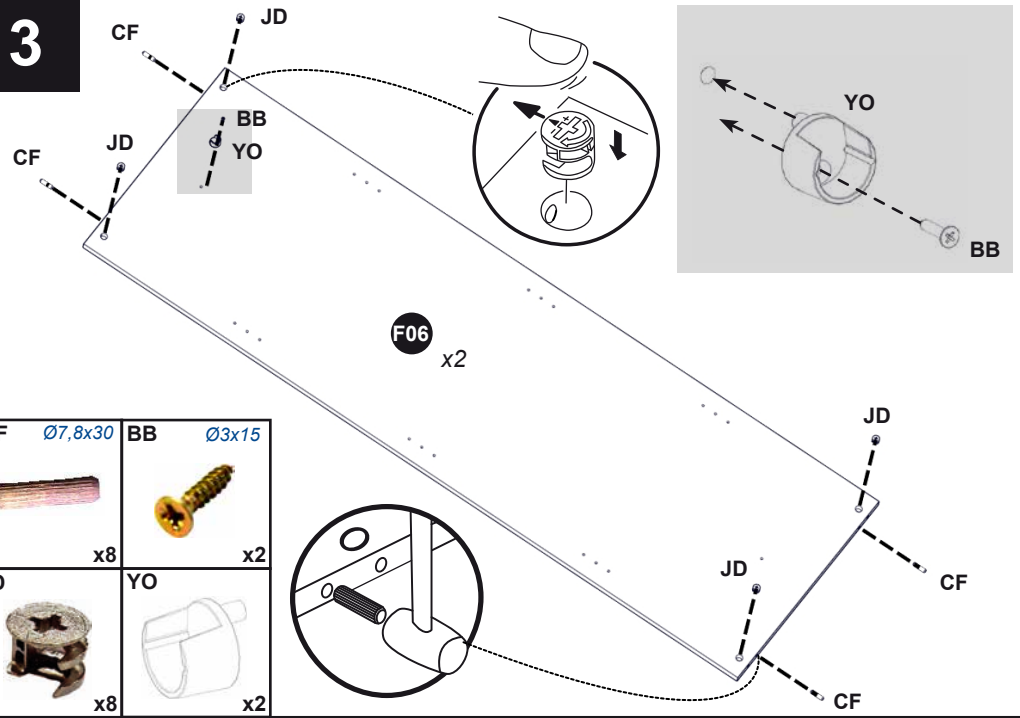

4

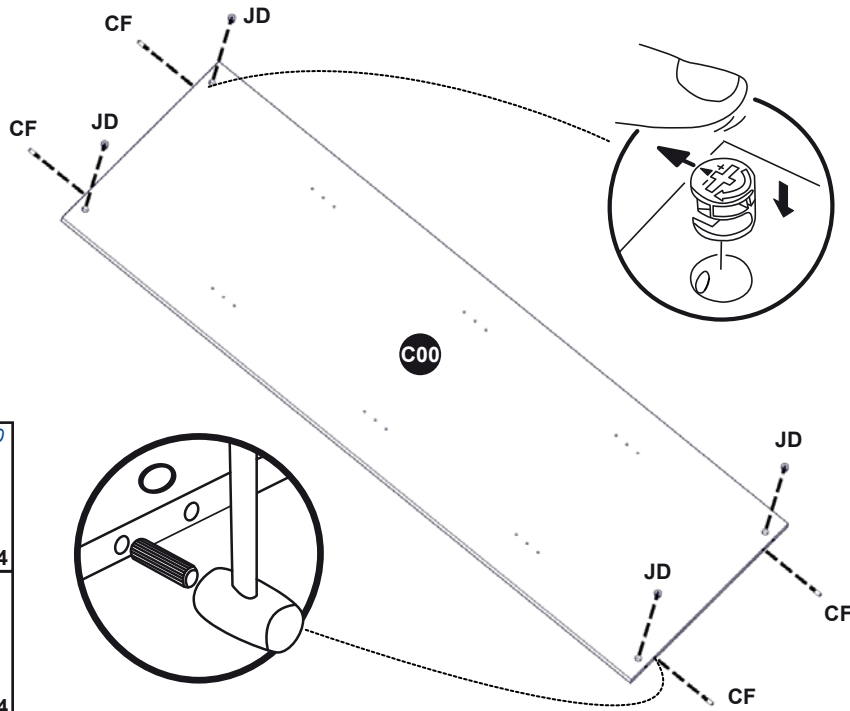

CF Ø7,8x30



x4

JD



x4

5

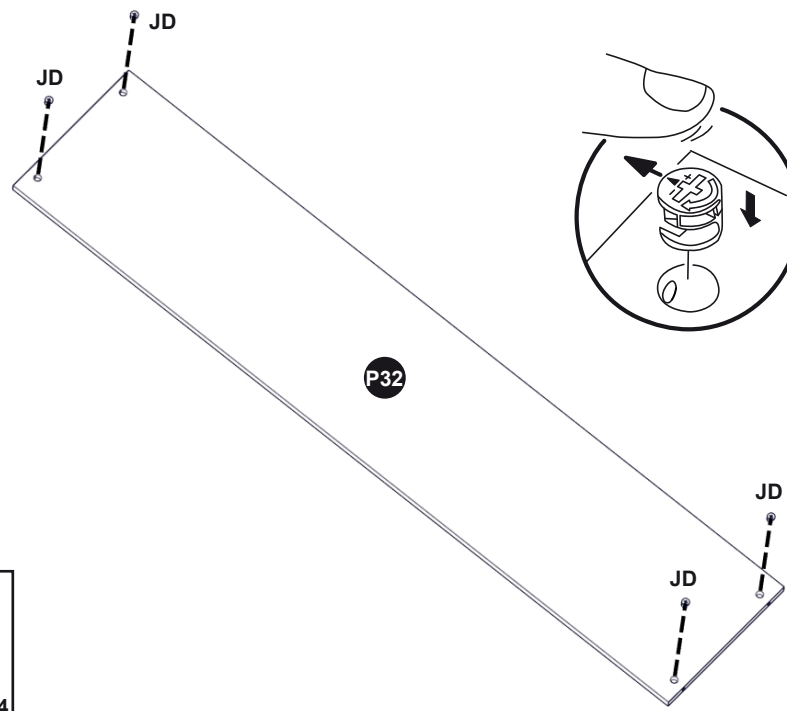

JD



x4

6

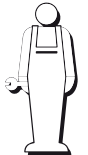

x2

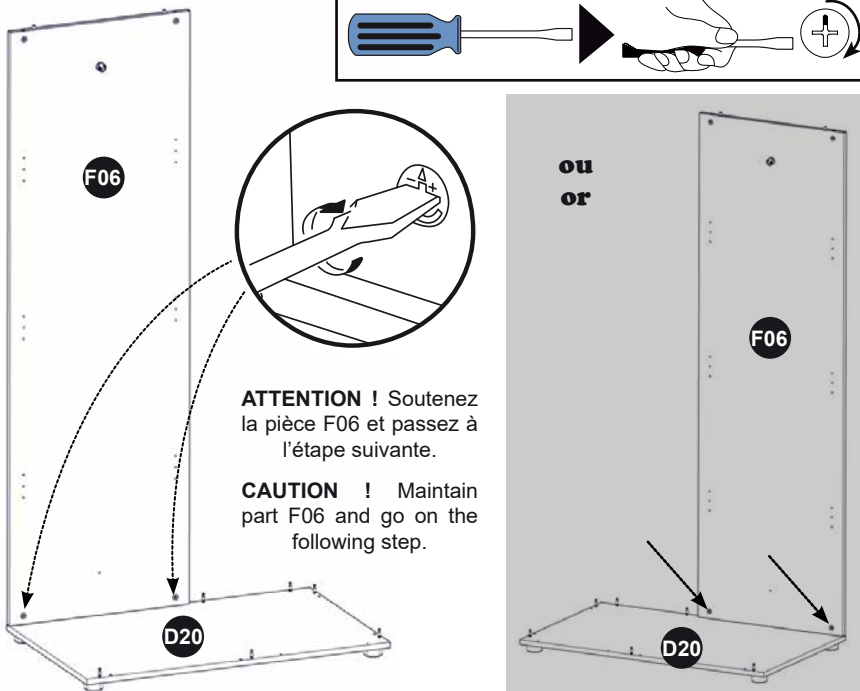

**ATTENTION !** Soutenez la pièce F06 et passez à l'étape suivante.

**CAUTION !** Maintain part F06 and go on the following step.

ou  
or

7

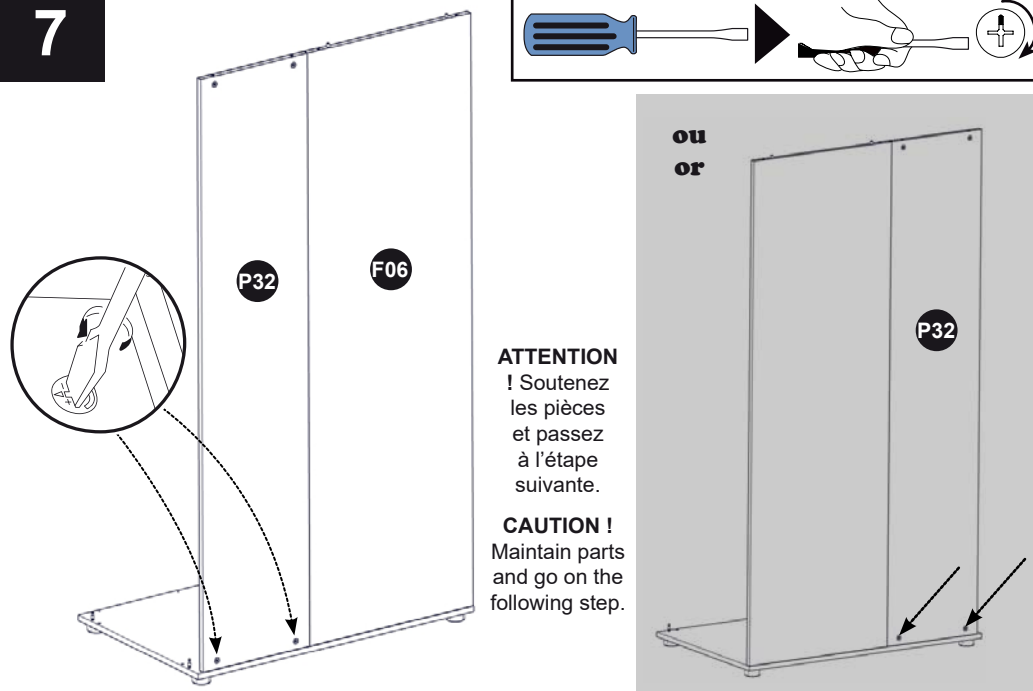

**ATTENTION !** Soutenez les pièces et passez à l'étape suivante.

**CAUTION !** Maintain parts and go on the following step.

ou  
or

8

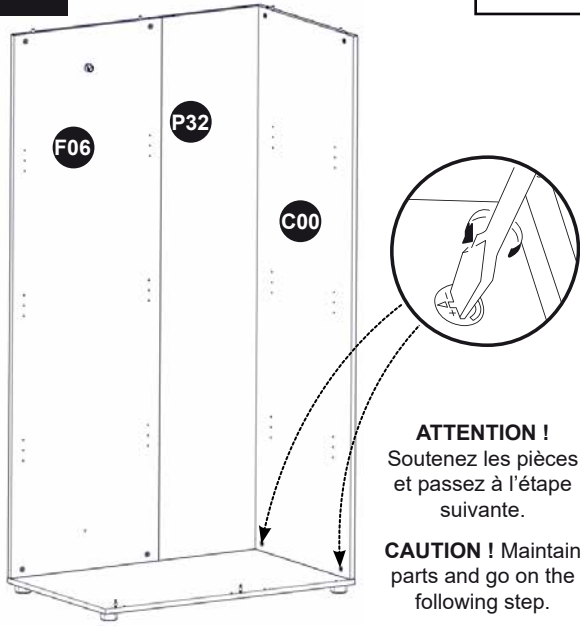
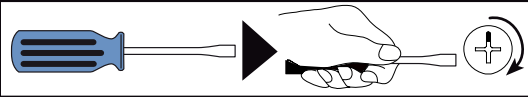

**ATTENTION !**  
Soutenez les pièces  
et passez à l'étape  
suivante.

**CAUTION !** Maintain  
parts and go on the  
following step.

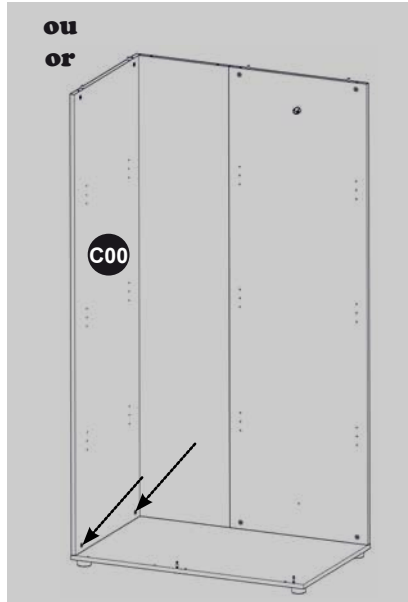

9

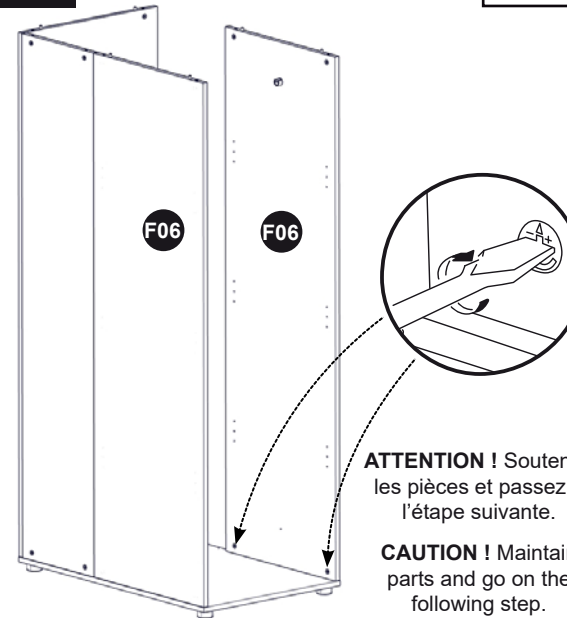
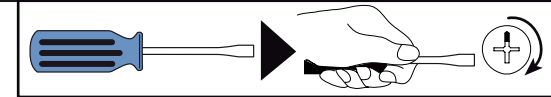

**ATTENTION !** Soutenez  
les pièces et passez à  
l'étape suivante.

**CAUTION !** Maintain  
parts and go on the  
following step.

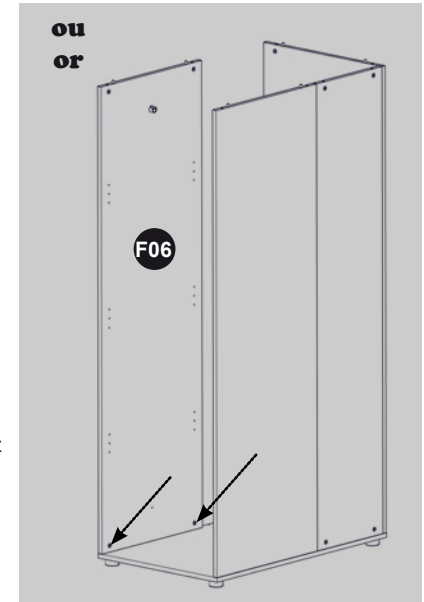

10

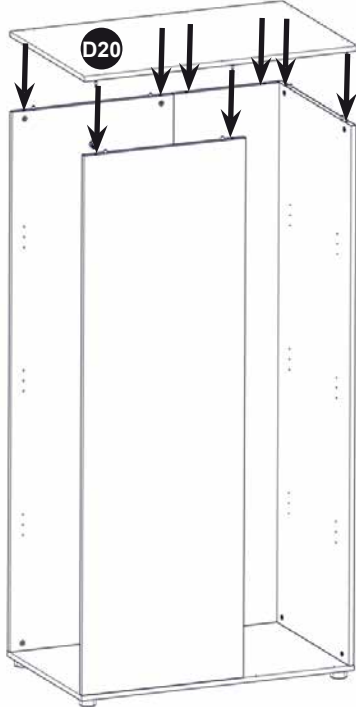

11

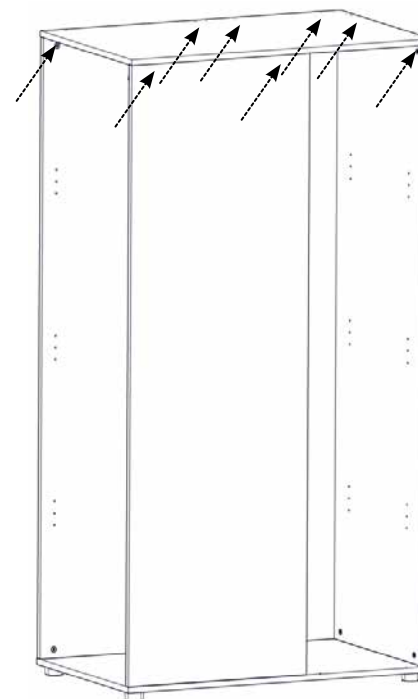
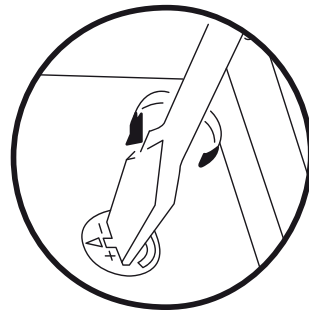
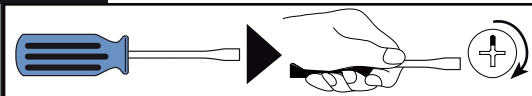

ou  
or

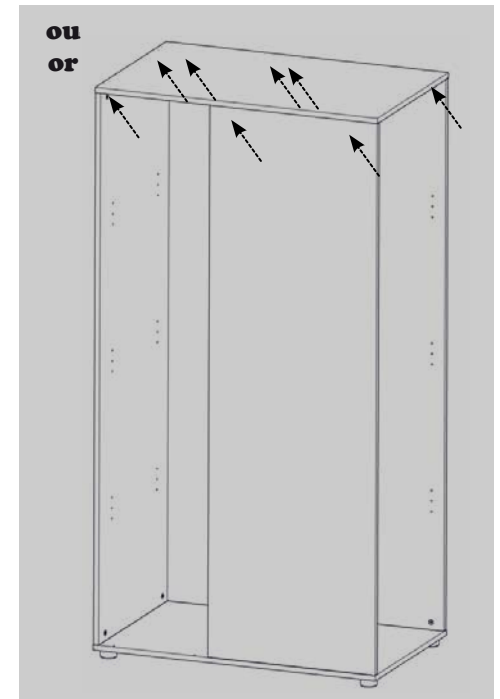

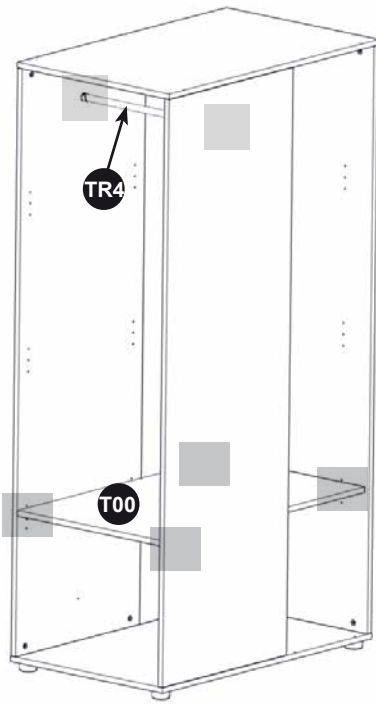
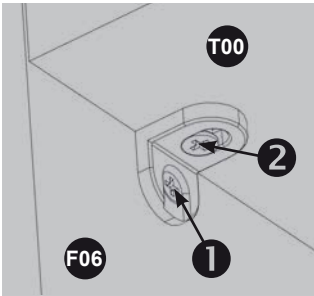
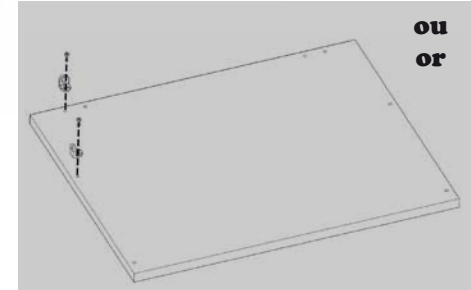
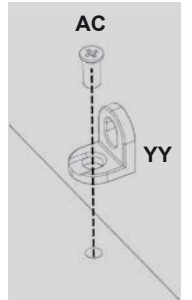
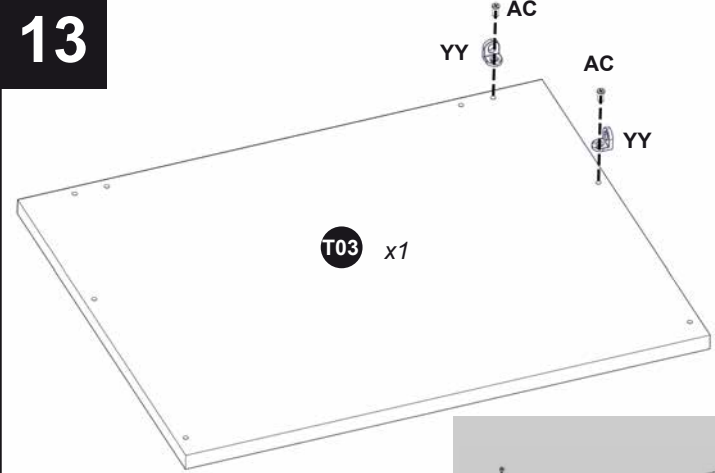
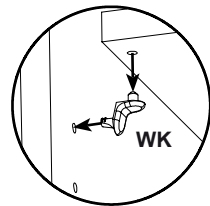
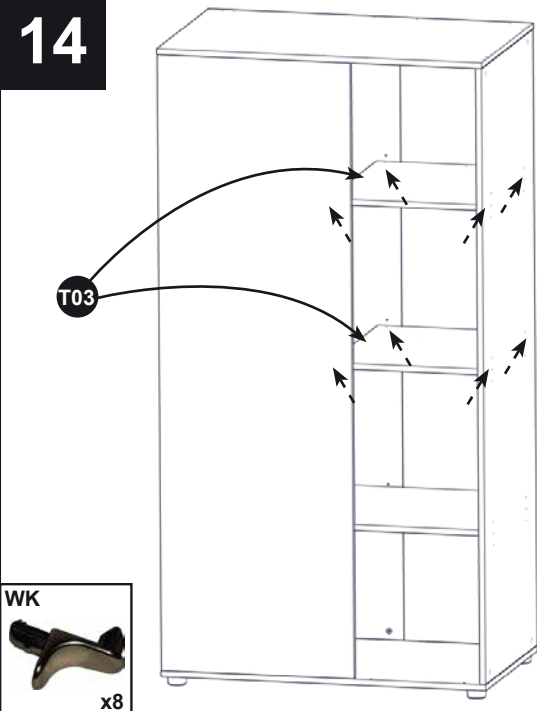
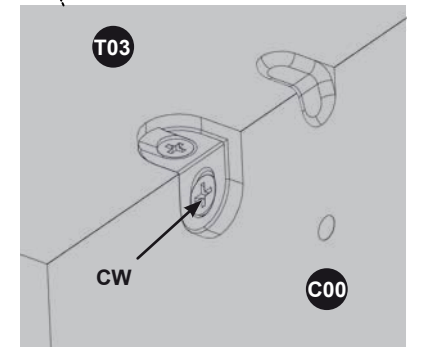
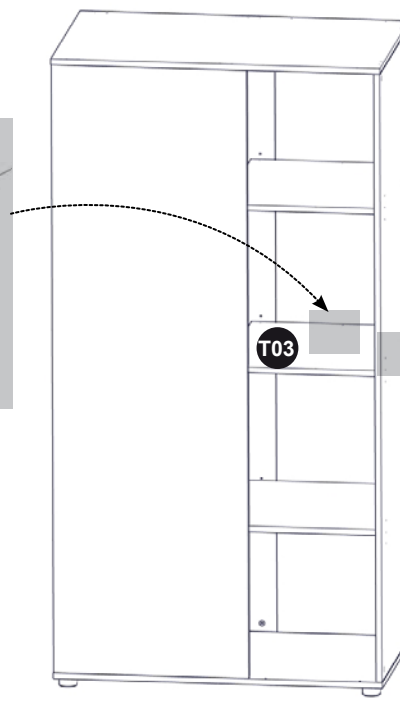
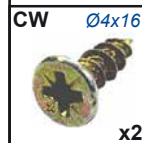
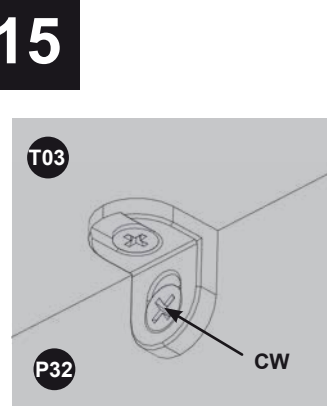
**12****F06****TR4****YO****TR4****ou  
or****TR4****T00****T00****T00****2****1****F06****YY****AC Ø6x11****x4****x8****13****YY****AC****AC****YY****T03 x1****AC****YY****ou  
or****AC Ø6x11****YY****x2****x2****14****T03****ou  
or****T03****T03****WK****x8****15****T03****P32****CW****T03****T03****CW****C00****CW Ø4x16****x2**

## DERNIERS REGLAGES

## FINAL ADJUST- MENTS

Pour un bon fonctionnement de l'armoire, il est indispensable de caler correctement celle-ci. Utilisez une ou plusieurs cales adaptées (épaisseur) de façon à obtenir un jeu régulier entre le dessus et les portes.

Veillez aussi à resserrer périodiquement les assemblages.

For a good using of the wardrobe, it is essential to steady correctly this one. Use one or several adapted wedges (thickness) in order to have a regular space between the top and the doors. Screw up regularly assembling parts please.

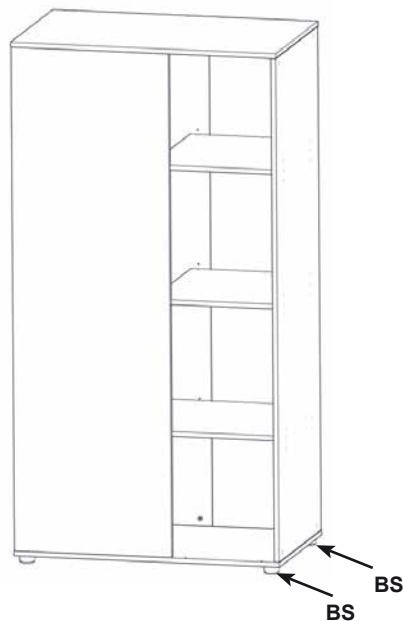
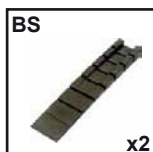

## DISPOSITIF ANTI - BASCULE

La vis fournie avec le dispositif anti-bascule est destinée à fixer le dispositif dans le meuble. Pour la fixation au mur, compléter par une vis adaptée au support mural. En cas de doute, contacter un magasin de bricolage.

## FALLOVER-PROOF DEVICE

Screw supplied with the fallover-proof device must be used to fix the device in to the piece of furniture. For the fixation to the wall, complete it by a screw adapted to the wall bracket. In case of doubt, contact a DIY store.

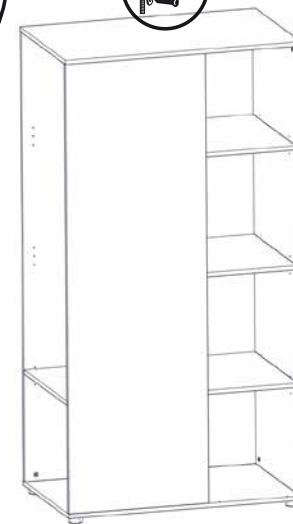
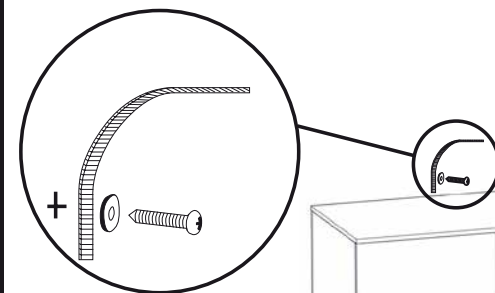

# 16

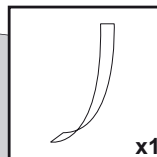
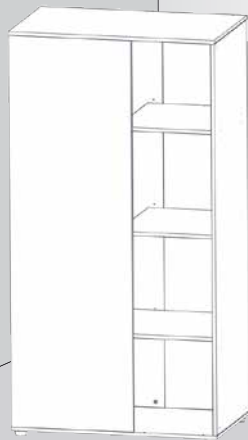

# 17

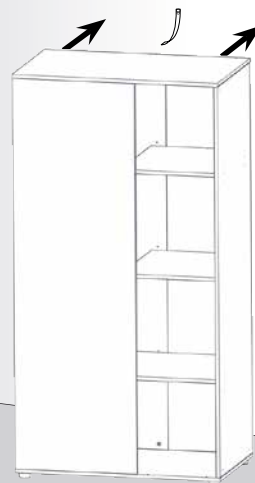

# 18

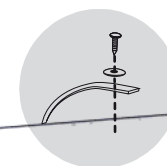

D20

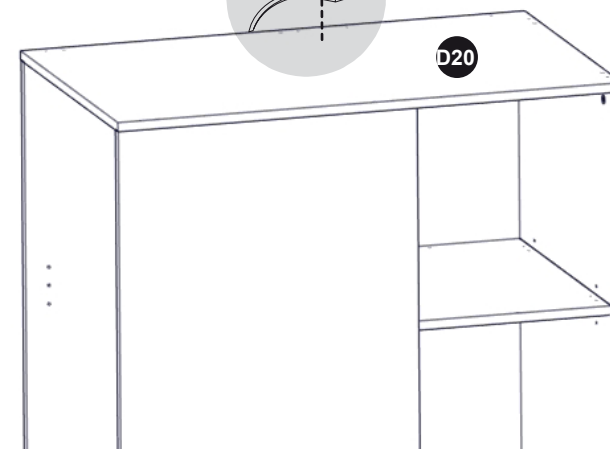

**F** GABARIT POUR FIXATION DES 4 PIEDS D'ANGLES :

Utiliser le schéma ci-contre en le plaçant sur la pièce D12 afin de la marquer à chaque angle, pour ensuite fixer les pieds.

**GB** MODEL FOR BINDING OF 4 CORNER FEET :

Use this model beside and put it in the part D12 to drill it in each corner and then to fit the feet.

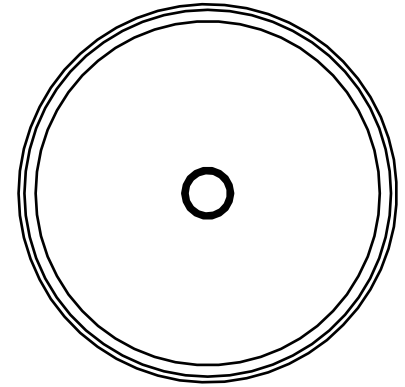

FEUILLET A DETACHER / PAGE TO TAKE OUT